

FRESH AIR FOR YOUR LIFE



VENT-ECO **PRO**

Energy Heating Recovery Unit



We breathe in
18kg^{*1} of
AIR
a person a day

Envi Group is dedicated to
deliver fresh air for your life.

Our aim is to create Total Air Solutions that let you
enjoy perfect Building Air Quality.

 **FOOD**
1.3kg^{*2}
a person
a day

 **WATER**
1.2kg^{*3}
a person
a day

**FRESH AIR IS ESSENTIAL TO IMPROVE BUILDING AIR QUALITY.
WE IMPROVE THE QUALITY OF AIR,
SO YOU CAN ENJOY THE QUALITY OF LIFE.**

FRESH AIR MAKES YOU HEALTHY

FRESH AIR MAKES YOU IMPROVE WORK EFFICIENCY

FRESH AIR MAKES YOU COMFORTABLE

FRESH AIR MAKES YOU SLEEP BETTER

FRESH AIR FOR YOUR LIFE

• *1 : Iwao Uchiyama (Department of Occupational Health, National Institute of Public Health) "Air and Human Beings: from the Physiological Viewpoint" (1999) <https://ci.nii.ac.jp/naid/110008447936/>

• *2, *3 : Heat illness Prevention (Chapter 3) in "Heat illness Environmental Health Manual 2018", P.32, Figure3-2 by Ministry of the Environment, Government of Japan. http://www.wbgt.env.go.jp/pdf/manual/heatillness_manual_3-1.pdf

Model Descriptions

EHRUV - **D** **150** - **2** **A** **1** **B**

1 2 3 4 5 6 7

- 1 VENT-ECO PRO energy heating recovery unit
- 2 Installation type, D for suspended type
- 3 Rated airflow (m³/h), for airflow more than 1000m³/h, H is for a hundred
- 4 Series Code
- 5 A is built in PM2.5 filter, B is without PM2.5 filter
- 6 1 is without bypass, 2 is with bypass.
- 7 No alphabet is standard control, A is for advanced intelligent control, B is for black cool intelligent control

VENT-ECO PRO

Heating Recovery Unit



EHRUV-D150-2A1/EHRUV-D250-2A1/EHRUV-D350-2A1/
EHRUV-D150-2B1 / EHRUV-D250-2B1 /EHRUV-D350-2B1



Fresh air supply



Stale air exhaust



Physical filtering



Energy recovery



Slim design



EPS structure



Durable



Good insulation



Easy access



Silent operation



Energy saving



Smart control



Filter alarm



Central control



IAQ monitor

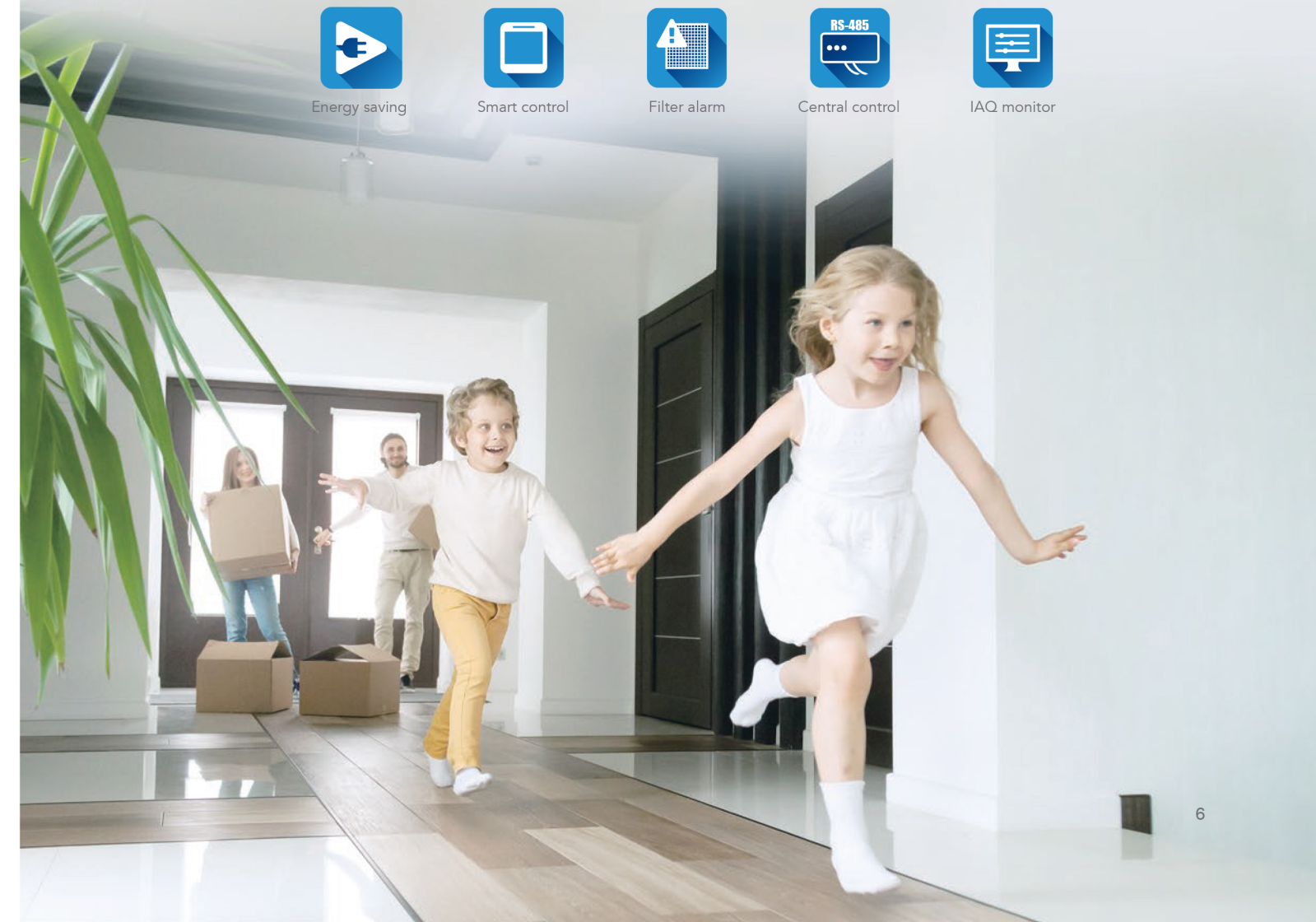

Durable appearance design

- Anticorrosive, beautiful, durable
- Excellent anti-corrosion performance
- Metallic texture



EPS structure

- Integrated EPS for good insulation and air tightness.
- No condensation.
- Light weight, heat preserve, silent, environmental friendly, no odor
- EPS is a high polymer material widely used for building insulation, floor heating, refrigeration, industrial casting and other industries.

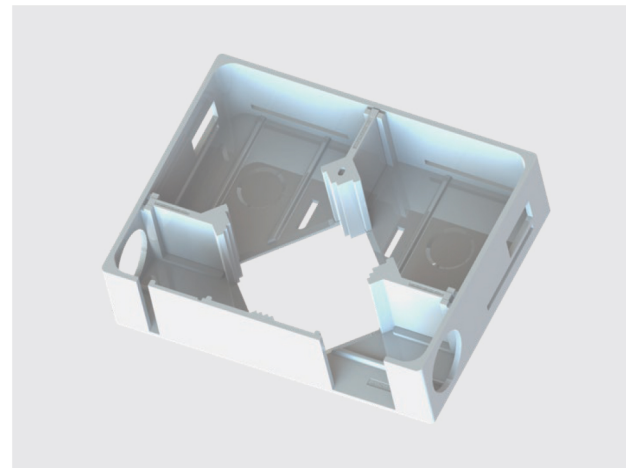

Supper slim body design

Vent-Eco Energy Heating Recovery Units are designed specially for the projects which have very strict ventilator height requirement, compared with the traditional congeneric products, vent-eco pro height is 20% off. Access door is at the bottom so maintenance is much easier.

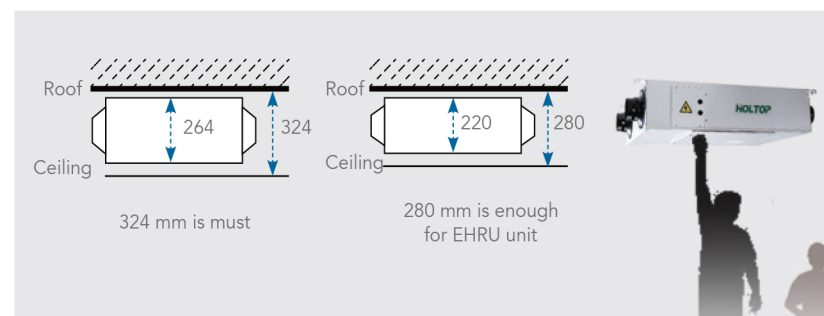

New primary filter

New primary filter is made of aluminium alloy frame and rubber filtration materials with nicer appearance and longer service life.

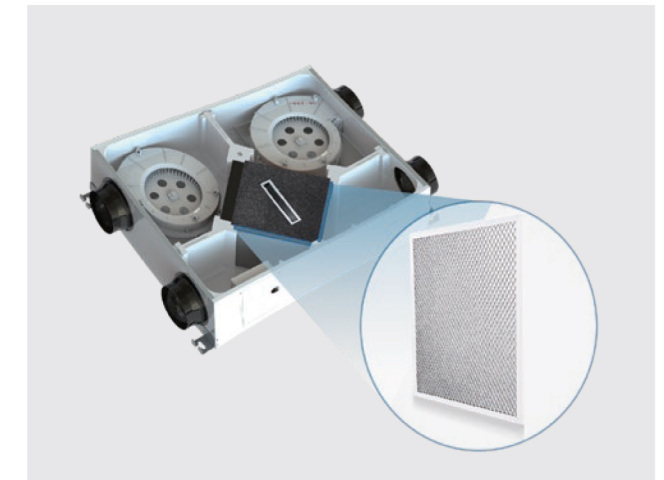

Sub-HEPA F9 filter integrated optional

Optional sub HEPA F9 filter, particle diameter under 2.5µm can be filtered effectively, IAQ (indoor air quality) will be increased obviously.

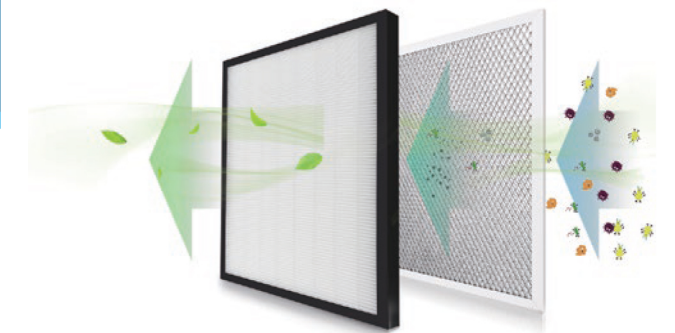

High efficiency temperature and humidity recovery

EnviGroup crossflow enthalpy exchanger is built in the full vent-eco pro series EHRU, heat recovery efficiency up to 82% in winter, the allowance of moisture exchange between fresh air and exhaust air make a comfortable indoor temperature and humidity.

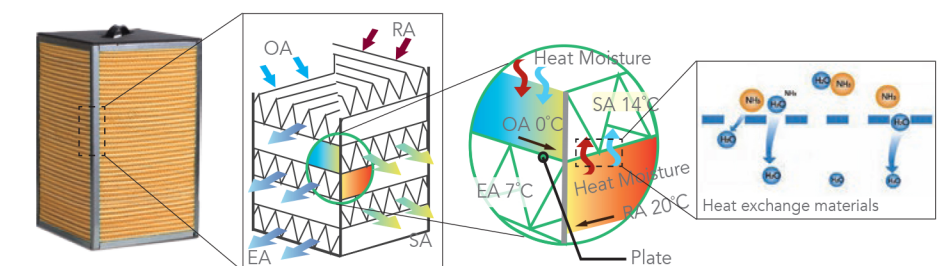

Specifications

Model	Fan Speed	Airflow (m³/h)	External pressure (Pa)	Enthalpy Eff.(%)		Temp. Eff. (%)	Noise dB(A)	Current (A)	Input power (W)	Volt. (V)	N. W. (Kg)
				Summer	Winter						
EHRUV-D150-2A1 EHRUV-D150-2B1	L	120	45	61	75	82	23	0.45	93	220	29
	M	150	70	59	73	80	31	0.46	98		
	H	150	90	59	73	80	31.5	0.47	102		
EHRUV-D250-2A1 EHRUV-D250-2B1	L	210	35	57	70	75	26.5	0.58	123	220	32
	M	250	50	55	68	73	33.5	0.60	148		
	H	250	100	55	68	73	34	0.71	150		
EHRUV-D350-2A1 EHRUV-D350-2B1	L	240	40	62	73	81	31	0.97	209	220	42
	M	350	110	57	68	76	36.5	1.05	230		
	H	350	130	57	68	76	37	1.07	233		

Dimensions

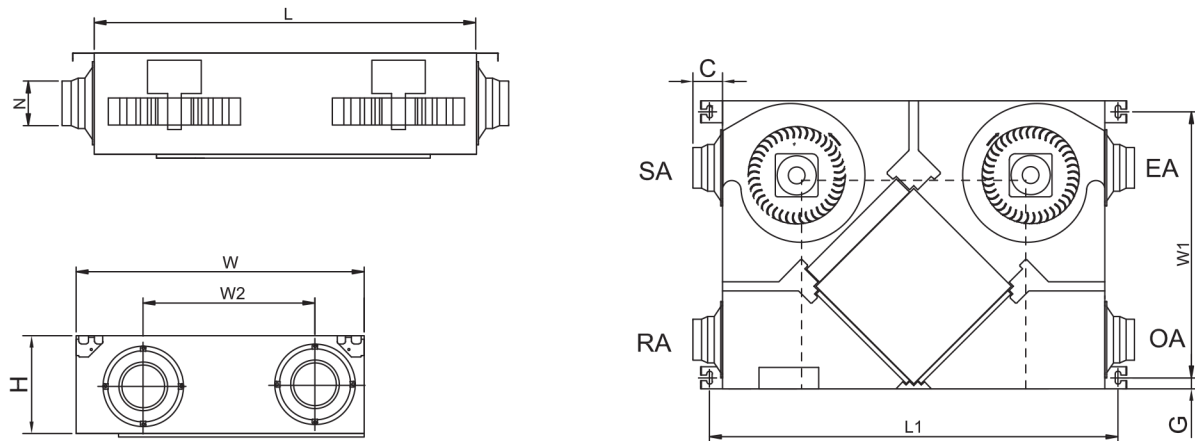

Model	L	L1	W	W1	W2	H	H1	C	G	N
EHRUV-D150-2A1 EHRUV-D150-2B1	860	920	685	618	405	220	-	70	26	Ø98
EHRUV-D250-2A1 EHRUV-D250-2B1	930	990	700	633	425	220	-	70	26	Ø144
EHRUV-D350-2A1 EHRUV-D350-2B1	1070	1130	820	753	550	230	-	70	26	Ø144



EHRUV-D600-2B2~EHRUV-D13H-2B2

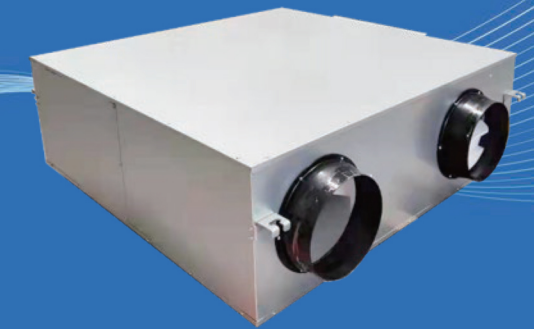

EHRUV-D600-2A2~EHRUV-D13H-2A2



Fresh air supply



Stale air exhaust



Physical filtering



Energy recovery



EPS structure



Durable



Good insulation



Easy access



Silent operation



Bypass function



Energy saving



Smart control



Filter alarm



Central control



IAQ monitor



Good thermal insulation

The whole series are intergrated with EPS structure, effectively preventing condensation, and improving thermal insulation and saving energy consumption.

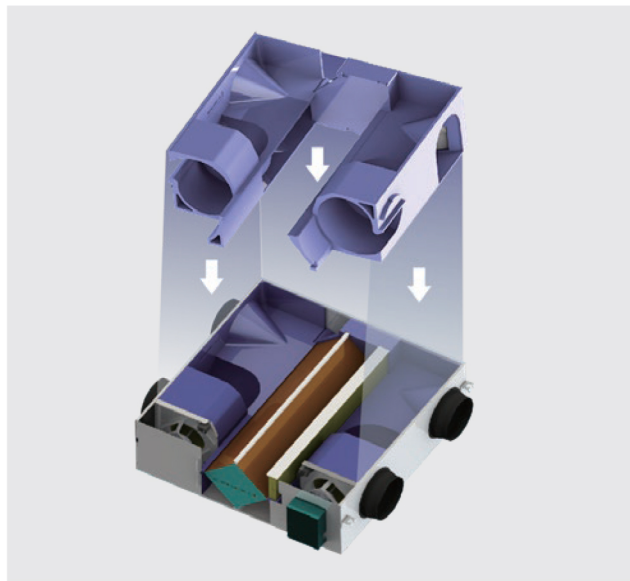

New primary filter

New primary filter is made of aluminium alloy frame and rubber filtration materials with nice appearance and longer service life.



New compact structure

New airflow channels are to increase heat exchange surface and improve energy recovery efficiency.

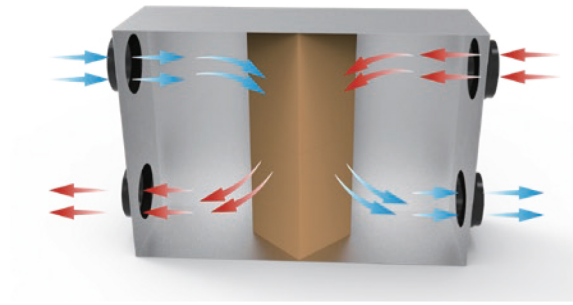

Easy maintenance

- Regular access door is for maintenance of primary filter, PM2.5 filter and heat exchangers.
- Increase two professional access doors for the control and fan maintenance.

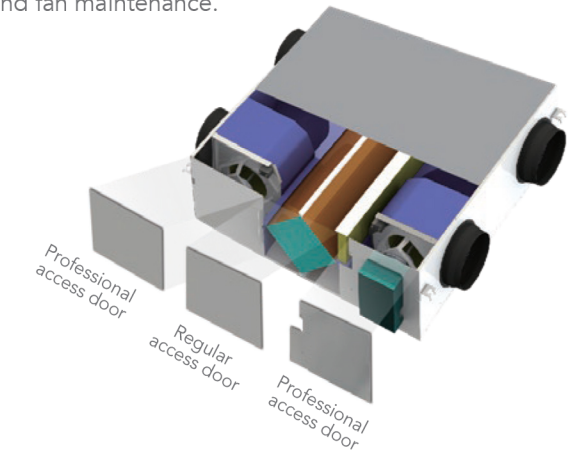

Higher efficiency with 3rd generation enthalpy exchanger

The 3rd generation enthalpy exchanger is made of the latest nanofiber structure to ensure higher efficiency. The heat exchange materials are mildew resistance and fire retardance.

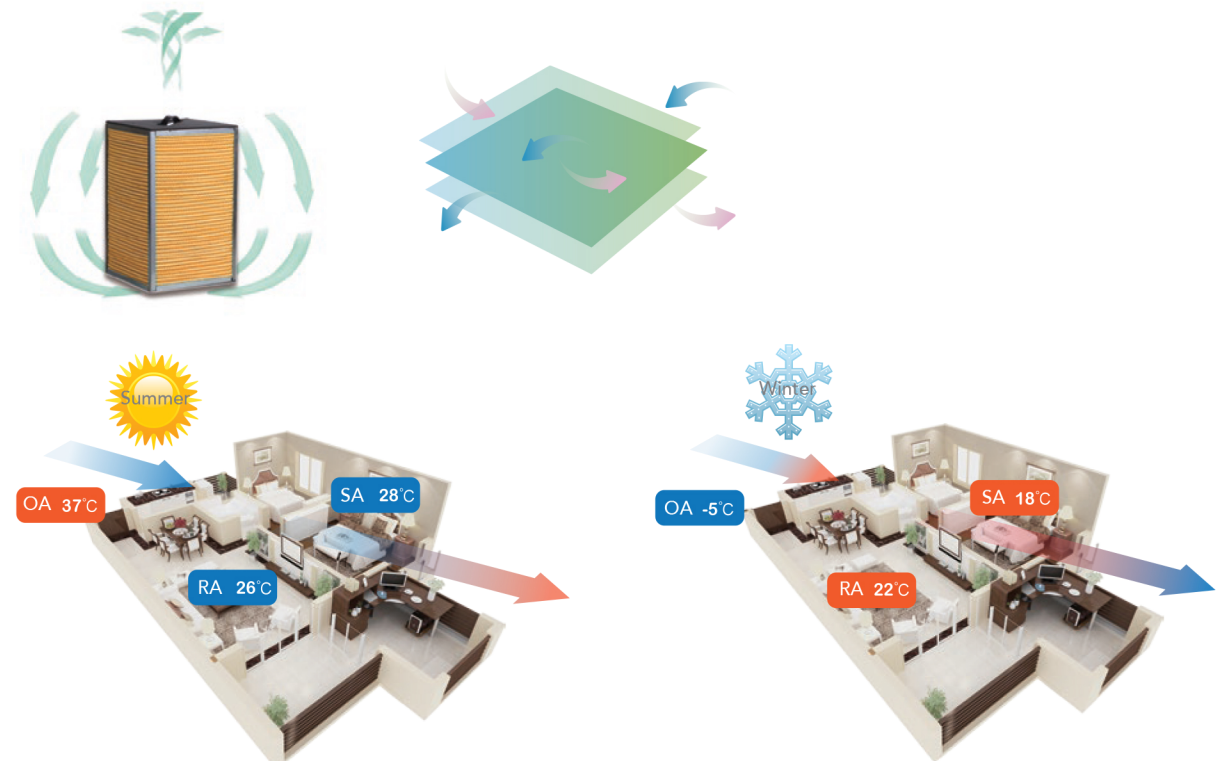

Sub-HEPA F9 filter integrated optional

Optional sub HEPA F9 filter, particle diameter under 2.5µm can be filtered effectively, IAQ (indoor air quality) will be increased obviously.



Specifications

Model	Fan Speed	Airflow (m³/h)	External pressure (Pa)	Enthalpy Eff.(%)		Temp. Eff. (%)	Noise dB(A)	Current (A)	Input power (W)	N. W. (Kg)	Remarks
				Summer	Winter						
EHRUV-D600-2B2	L	500	89	63	67	76	29	0.96	200	34	Without PM2.5 filters
	M	600	92	59	61	70	35				
	H	600	97	59	61	70	39				
EHRUV-D800-2B2	L	700	92	57	63	74	34	2	420	53	
	M	800	96	55	57	68	39				
	H	800	100	55	57	68	41				
EHRUV-D10H-2B2	L	900	80	60	64	76	34	2.1	450	61	
	M	1000	85	58	62	70	38				
	H	1000	86	58	62	70	42				
EHRUV-D13H-2B2	L	1000	75	58	62	76	38	3.2	680	71	
	M	1300	85	56	59	70	41				
	H	1300	90	56	59	70	43				
EHRUV-D600-2A2	L	500	79	63	67	76	29	0.92	200	35	With PM2.5 filter
	M	600	85	59	61	70	35				
	H	600	87	59	61	70	39				
EHRUV-D800-2A2	L	700	82	57	63	74	34	2	420	54	
	M	800	86	55	57	68	39				
	H	800	90	55	57	68	41				
EHRUV-D10H-2A2	L	900	70	60	64	76	34	2.1	450	62	
	M	1000	76	58	62	70	38				
	H	1000	76	58	62	70	42				
EHRUV-D13H-2A2	L	1000	65	58	62	76	38	3.2	680	72	
	M	1300	80	56	59	70	41				
	H	1300	80	56	59	70	43				

Dimensions

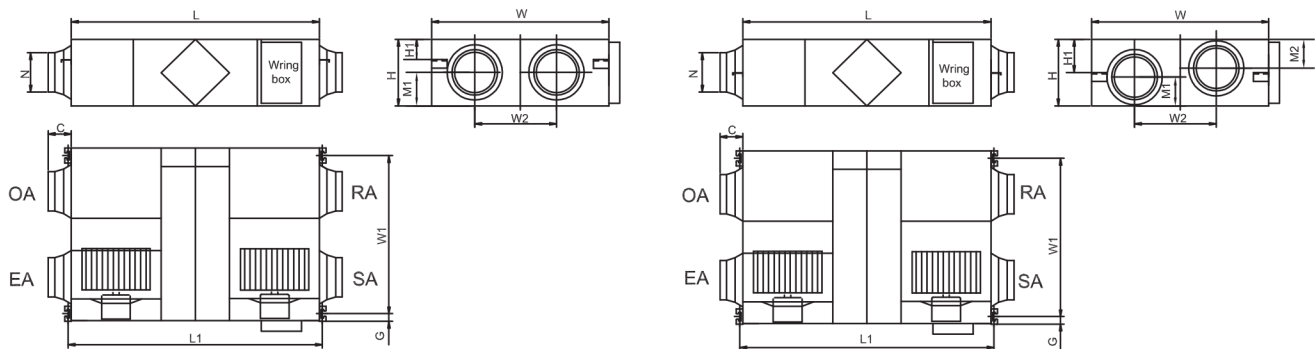



EHRUV-D600-2B2~EHRUV-D10H-2B2, EHRUV-D600-2A2~EHRUV-D10H-2A2

EHRUV-D13H-2B2, EHRUV-D13H-2A2

Model	L	L1	W	W1	W2	H	H1	C	G	M1	M2	N
EHRUV-D600-2B2, EHRUV-D600-2A2	867	922	902	833.5	451.5	280	115.5	107	26	139.5	/	Ø194
EHRUV-D800-2B2, EHRUV-D800-2A2	1134	1189	884	818	378	388	128	85	26	194	/	Ø242
EHRUV-D10H-2B2, EHRUV-D10H-2A2	1134	1189	1134	1068	628	388	128	85	26	194	/	Ø242
EHRUV-D13H-2B2, EHRUV-D13H-2A2	1193	1248	1243	1173	629.5	388	133	85	26	139.5	241	Ø242



Standard Controller

Standard controller	 EDK-19V-E	 EDK-19S-E
Suitable models	EHRUV-D150~D350-2A1, EHRUV-D600~D13H-2A1	EHRUV-D600~D13H-2B1
Temperature display	✓	✓
Time display	✓	✓
Day display	✓	✓
Weekly timer	✓	✓
Speed selection	✓	✓
Auto/Manual mode selection	✓	✓
Bypass	✓	✓
Filter alarm	✓	✓
Lock screen function	✓	✓
Indoor air quality monitor	✓	✗
RS485 connector	✓	✓

Intelligent Controller

Intelligent control	 EDK-CK-20	 EH-12100	 E-10307	
Type	Black cool intelligent control		Advanced intelligent control	
Suitable series	EHRUV-D600~D13H-2B2 EHRUV-D600~D13H-2A2	EHRUV-D150~D350-2A1 EHRUV-D150~D350-2B1	EHRUV-D600~D13H-2B2 EHRUV-D600~D13H-2A2	EHRUV-D150~D350-2A1 EHRUV-D150~D350-2B1
Temperature display	OA/RA/SA/FR temp.		OA/RA/SA/FR temp.	
10 speed	✓		✓	
Weekly timer	✓		✓	
Bypass	Auto	✗	Auto	✗
External ON/OFF	✓		✓	
Comfortable heater control	✓		✓	
Defrosting	✓		✓	
CO ₂ control	✓		✓	
Filter alarm	✓		✓	
Fault alarm	✓		✓	
Data memory	✓		✓	
Night free cooling	✓	✗	✓	✗
BMS integration	✓		✓	
Humidity control	✓		✓	
Defrosting heater control	✓		✓	
Working condition monitor	✓		✓	
Sleep mode	✓		✗	✗
Wifi function	✗		✓	

*The is a MOQ for intelligent controller EH-12100 and E-10307



■ Monitoring indoor air quality

Monitor local weather, temperature, humidity, CO₂ concentration, VOC at your hand for healthy living.

■ Variable setting

Timely switch, speed settings, bypass/timer/filter alarm/temperature setting.

■ Optional language

Different language English/French/Italian/Spanish and so on to meet your requirement.

■ Group control

One APP can control multiple units.

