



## TRENCH HEATERS FCH

 FOR HEATING

 FOR COOLING

 FAN ASSISTED

- 10 models
- Stainless steel casings
- 2 and 4 pipes versions
- Wet cooling and dry cooling ready
- Remarkably low noise level
- Tested according to EN16430 in independent accredited laboratory
- 10 year warranty for casings and heat exchangers
- Fans with most economical and quiet EC type motors
- High rise of cooled air
- Excellent compatibility with heat pumps and condensate boilers
- Max operating pressure 25 bar
- Possibility to control up to 30 units with 1 room thermostat
- Highly efficient and economic copper-aluminium heat exchangers
- Safe voltage of fans – 24V (DC)
- Supply air filters are in standard set
- Reversible reinforced profile grilles
- All fixing brackets and bolts have sound proofing elements
- Possibility to change level of casing at any time during exploitation (when installed in raised floors)



2021

FCH



# TRENCH HEATERS FCH

FCH are among the most powerful trench heaters designed for **heating and cooling**.

Both heated and cooled air is raised right up the ceiling to result in an **even distribution** throughout the room.

**4 and 2 pipe connection versions are available.** The 4 pipe connection guarantees maximum flexibility, whereas the 2 pipe connection will ensure the maximum capacity.

**The air flow** passing through the appliance is **continuously filtered** to trap a considerable part of the dust and dirt in the room and protect the heater from contamination.

Include **drain pans** that allow the device to operate both above and below the dew point.

**Quiet and extremely economical EC fans** increase the convection efficiency more than 4 times, almost without any sound.

Due to **extremely low inertia**, can quickly increase and precisely maintain the set room temperature, **providing the room with exactly as much heat as you require just when it is required.**

Create an effective warm air curtain for large windows, without allowing cold to penetrate the premises. The **heat is perfectly distributed** throughout the room.

Operates very well with **low-temperature heat sources**, such as heat pumps or condensing boilers.

Fully integrated into the floor, and therefore **do not impede free passage.**

**Perfect for any interior**, as the only visible element is the grill, the material and colour of which matches floor covering.

May be walked on and can easily **withstand the weight of a number of adults.**

Supplied with a **stainless steel casings** and **copper-aluminium heat exchangers**, to ensure they remain extremely reliable over the long-term.



### 10-year warranty for the casings and heat exchangers

We are confident in the longevity of our housings and heat exchangers; therefore, we provide them with a 10-year guarantee.



### Tested according to EN16430

The outputs of all products manufactured by Konveka have been tested by independent accredited laboratories according to the latest standards.

**With us, 1 kW means 1 kW.**



### Fans with EC technology

All Konveka forced convection devices are equipped with fans that employ **EC technology**. This is far superior to AC technology, as the fans:

1. Are **7 times more economical**.
2. Brushless motors are more durable and are **maintenance-free**.
3. Speed is **adjustable stepless**, using only as much power as required.
4. Starting currents do not exceed the operating currents.
5. Minimum rotation speed is 10% (out of max.)



### Work perfectly with low-temperature energy carriers

Due to their high efficiency, FCH are very **suitable for** operating with low-temperature energy carriers, such as **heat pumps** and **condensing boilers**.



### Sound insulation

All the supporting parts have sound-insulating elements, to prevent the spread of sound to the premises below.



### Especially quiet operation

We have achieved exceptionally low noise levels using **extremely quiet EC fans** and by the **optimisation** of their **rotational speed** and **design** of the devices.



**All body parts are made of stainless steel** Stainless steel provides **100% corrosion protection** for an indefinite time. It is also **54% stronger** and **45% harder** than carbon steel, so it can withstand loads during transportation, installation, and operation.



### Reinforced casings

As a standard, the FCH convector casings are equipped with:

1. **Stiffening elements** to maintain the pressure of the concrete – from 2 to 3 pcs, depending on the length of the casing.
2. M10 **support screws** to withstand the vertical load – from 4 to 12 pcs.
3. Mounting **brackets** for attaching the casing to the floor – 4 pcs.

These structural elements, together with the strong casing material, ensure their stable shape during installation, transportation and operation.



### Maximum operating pressure – 25 bar

All the devices are **factory-tested** for leaks at a pressure of **30 bar**. The maximum maintained pressure (strength limit) is **110 bar**. Konveka devices easily withstand hydraulic tests, hydraulic shocks and can be installed in extremely tall buildings.



### Safe operating voltage of fans

The operating voltage of all fans is 24V DC. This voltage is safe for humans.

## STANDARD SET

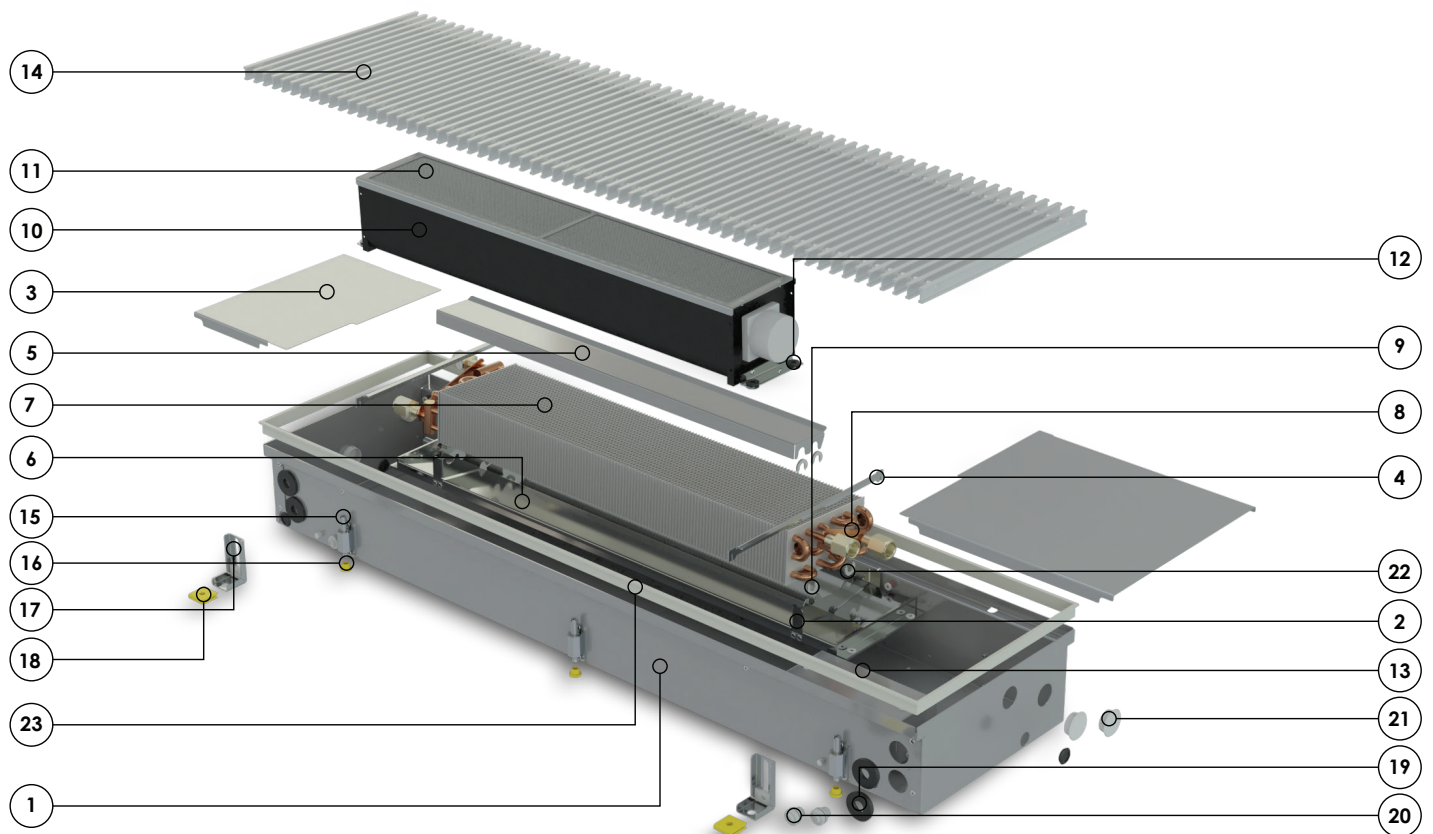

FCH

- |   |   |   |  |
|---|---|---|--|
| ① | Stainless steel casing                      | ⑮ | Height adjustment and vertical load supporting bolts   |
| ② | Brackets for heat exchanger                 | ⑯ | Noise isolating elements for adjusting screws  |
| ③ | Hydraulic connections cover                 | ⑰ | Casing fixing to the floor brackets  |
| ④ | Casing's stiffening elements                | ⑱ | Noise isolation elements for floor brackets  |
| ⑤ | Air guiding element                         | ⑲ | Pipe sealing and protection elements   |
| ⑥ | Drain pan                                   | ⑳ | Cable sealing and protection elements  |
| ⑦ | Copper - aluminium heat exchanger           | ㉑ | Plugs for unused casing holes  |
| ⑧ | Air vent                                    | ㉒ | Anodized aluminium frame; colour matches the colour of grille  |
| ⑨ | Heat exchanger fixing - protecting elements |   | All fasteners required for installation  |
| ⑩ | Fan with EC motor                           |   | Installation manual  |
| ⑪ | Air filter                                  |   | 5-layer, 2 parts cardboard box, additionally used for device protecting during installation and construction works |
| ⑫ | Vibration dampers for fan                   |   |  |
| ⑬ | Control box (optional)                      |   |  |
| ⑭ | Protective - decorative grille (optional)   |   |  |



# FCH2

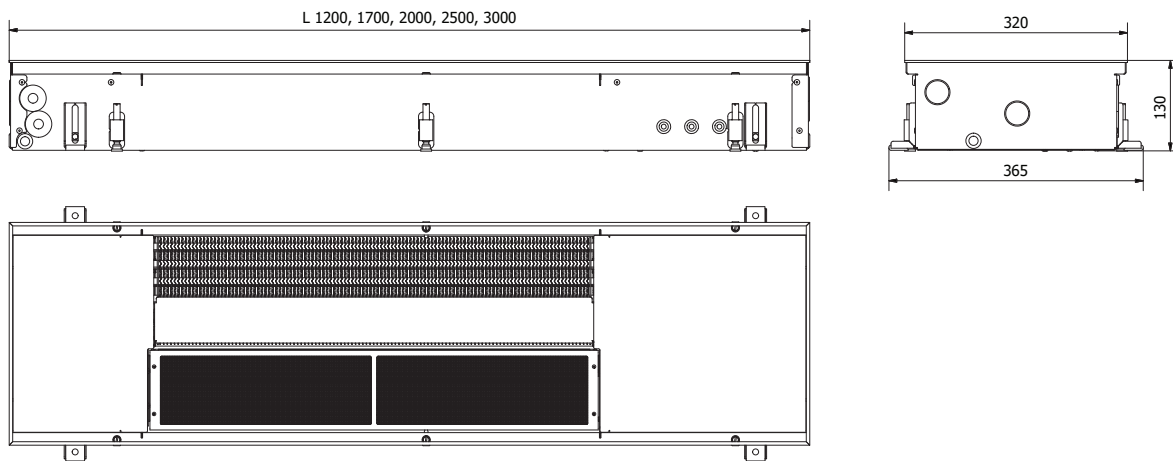

## TECHNICAL DATA

|                              |              |                                   |           |
|------------------------------|--------------|-----------------------------------|-----------|
| Length                       | 1200-3000 mm | Thread of hydr. connections       | G 1/2"    |
| Width                        | 320 mm       | Thread type of hydr. connections  | inner     |
| Height = installation height | 130 mm       | Position of the hydr. connections | 1 side    |
| Type of fan motors           | EC           | Operating pressure                | 25 bar    |
| Fan operating voltage        | 24V DC       | Operating temperature             | 2 - 120°C |
| Fan speed control voltage    | 0 - 10V      |                                   |           |

## EN16430 certified outputs

| Fan speed       | Heat outputs, W         |                         |                           | Sensible cooling capacity, W |                          |                          | Sound levels                |                          | Air flow m <sup>3</sup> /h |
|-----------------|-------------------------|-------------------------|---------------------------|------------------------------|--------------------------|--------------------------|-----------------------------|--------------------------|----------------------------|
|                 | 75/65/20°C<br>Δt = 50°C | 55/45/20°C<br>Δt = 30°C | 35/30/20°C<br>Δt = 12,5°C | 7/12/27°C<br>Δt = 17,5°C     | 7/12/25°C<br>Δt = 15,5°C | 14/17/25°C<br>Δt = 9,5°C | Sound pressure level, dB(A) | Sound power level, dB(A) |                            |
| <b>FCH2 115</b> |                         |                         |                           |                              |                          |                          |                             |                          |                            |
| 100%            | <b>3 326</b>            | 1 975                   | 809                       | 974                          | <b>870</b>               | 552                      | 41                          | 49                       | 0 - 383                    |
| 80%             | <b>2 962</b>            | 1 759                   | 720                       | 815                          | <b>728</b>               | 462                      | 36                          | 45                       |                            |
| 60%             | <b>2 487</b>            | 1 477                   | 605                       | 652                          | <b>582</b>               | 369                      | 28                          | 37                       |                            |
| 40%             | <b>1 912</b>            | 1 135                   | 465                       | 475                          | <b>424</b>               | 269                      | 23                          | 32                       |                            |
| 20%             | <b>1 132</b>            | 672                     | 275                       | 277                          | <b>248</b>               | 157                      | 20                          | 29                       |                            |
| <b>FCH2 160</b> |                         |                         |                           |                              |                          |                          |                             |                          |                            |
| 100%            | <b>5 781</b>            | 3 433                   | 1 405                     | 1 755                        | <b>1 568</b>             | 994                      | 42                          | 51                       | 0 - 520                    |
| 80%             | <b>5 264</b>            | 3 126                   | 1 280                     | 1 473                        | <b>1 316</b>             | 835                      | 41                          | 50                       |                            |
| 60%             | <b>4 427</b>            | 2 629                   | 1 076                     | 1 174                        | <b>1 049</b>             | 665                      | 34                          | 44                       |                            |
| 40%             | <b>3 399</b>            | 2 019                   | 826                       | 856                          | <b>765</b>               | 485                      | 29                          | 38                       |                            |
| 20%             | <b>2 014</b>            | 1 196                   | 490                       | 500                          | <b>446</b>               | 283                      | 25                          | 35                       |                            |
| <b>FCH2 180</b> |                         |                         |                           |                              |                          |                          |                             |                          |                            |
| 100%            | <b>6 653</b>            | 3 951                   | 1 617                     | 1 949                        | <b>1 741</b>             | 1 104                    | 44                          | 53                       | 0 - 766                    |
| 80%             | <b>5 924</b>            | 3 518                   | 1 440                     | 1 630                        | <b>1 456</b>             | 924                      | 39                          | 48                       |                            |
| 60%             | <b>4 975</b>            | 2 954                   | 1 210                     | 1 303                        | <b>1 164</b>             | 738                      | 31                          | 41                       |                            |
| 40%             | <b>3 824</b>            | 2 271                   | 930                       | 949                          | <b>848</b>               | 538                      | 24                          | 34                       |                            |
| 20%             | <b>2 264</b>            | 1 345                   | 551                       | 554                          | <b>495</b>               | 314                      | 22                          | 32                       |                            |
| <b>FCH2 230</b> |                         |                         |                           |                              |                          |                          |                             |                          |                            |
| 100%            | <b>9 107</b>            | 5 408                   | 2 214                     | 2 730                        | <b>2 438</b>             | 1 546                    | 43                          | 54                       | 0 - 903                    |
| 80%             | <b>8 226</b>            | 4 885                   | 2 000                     | 2 289                        | <b>2 044</b>             | 1 296                    | 40                          | 50                       |                            |
| 60%             | <b>6 914</b>            | 4 106                   | 1 681                     | 1 826                        | <b>1 631</b>             | 1 034                    | 33                          | 43                       |                            |
| 40%             | <b>5 311</b>            | 3 154                   | 1 291                     | 1 331                        | <b>1 188</b>             | 754                      | 26                          | 37                       |                            |
| 20%             | <b>3 146</b>            | 1 868                   | 765                       | 777                          | <b>694</b>               | 440                      | 24                          | 33                       |                            |

| Fan speed       | Heat outputs, W         |                         |                           | Sensible cooling capacity, W |                          |                          | Sound levels                |                          | Air flow m <sup>3</sup> /h |
|-----------------|-------------------------|-------------------------|---------------------------|------------------------------|--------------------------|--------------------------|-----------------------------|--------------------------|----------------------------|
|                 | 75/65/20°C<br>Δt = 50°C | 55/45/20°C<br>Δt = 30°C | 35/30/20°C<br>Δt = 12,5°C | 7/12/27°C<br>Δt = 17,5°C     | 7/12/25°C<br>Δt = 15,5°C | 14/17/25°C<br>Δt = 9,5°C | Sound pressure level, dB(A) | Sound power level, dB(A) |                            |
| <b>FCH2 275</b> |                         |                         |                           |                              |                          |                          |                             |                          |                            |
| 100%            | <b>11 561</b>           | 6 866                   | 2 811                     | 3 511                        | <b>3 136</b>             | 1 989                    | 43                          | 54                       | 0 - 1 040                  |
| 80%             | <b>10 529</b>           | 6 253                   | 2 560                     | 2 947                        | <b>2 632</b>             | 1 669                    | 42                          | 53                       |                            |
| 60%             | <b>8 853</b>            | 5 258                   | 2 153                     | 2 348                        | <b>2 097</b>             | 1 330                    | 33                          | 44                       |                            |
| 40%             | <b>6 798</b>            | 4 037                   | 1 653                     | 1 712                        | <b>1 529</b>             | 970                      | 27                          | 38                       |                            |
| 20%             | <b>4 027</b>            | 2 392                   | 979                       | 999                          | <b>893</b>               | 566                      | 24                          | 35                       |                            |

| Model    | Length, mm | No. of fans, pc | Max el. power, A | Max el. power, W | Length of heat exchanger, mm | Weight, kg | Water volume, l |
|----------|------------|-----------------|------------------|------------------|------------------------------|------------|-----------------|
| FCH2 115 | 1 200      | 1               | 0,63             | 15               | 675                          | 21,2       | 0,77            |
| FCH2 160 | 1 700      | 1               | 0,75             | 18               | 1 189                        | 28,9       | 1,35            |
| FCH2 180 | 2 000      | 2               | 1,25             | 30               | 1 431                        | 33,9       | 1,62            |
| FCH2 230 | 2 500      | 2               | 1,38             | 33               | 1 945                        | 42,2       | 2,21            |
| FCH2 275 | 3 000      | 2               | 1,50             | 36               | 2 458                        | 51,5       | 2,79            |

FCH2

**EXAMPLE OF CONNECTIONS**

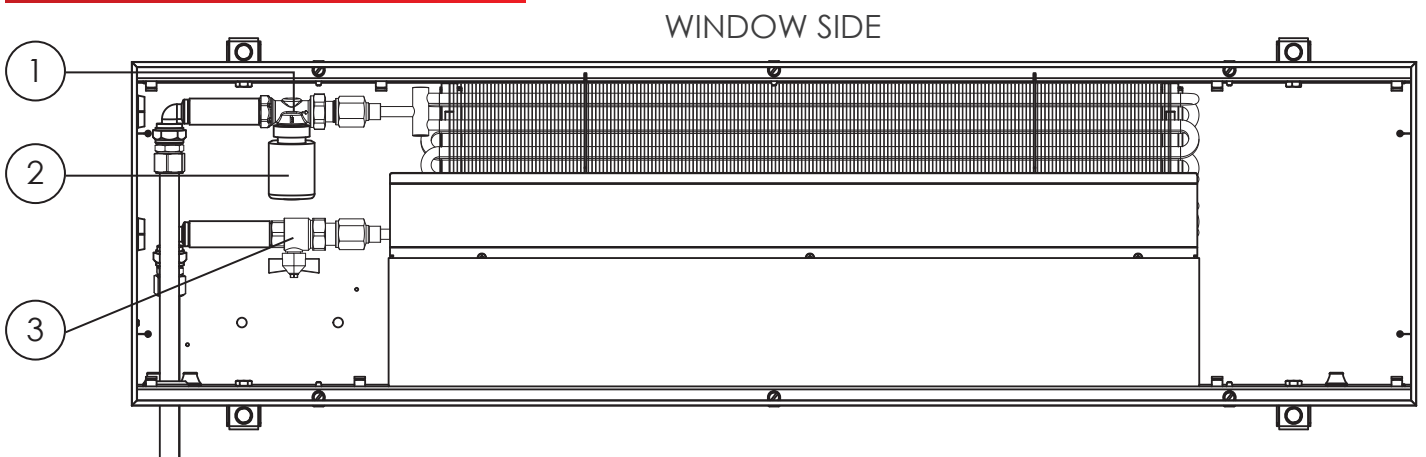

- ① Thermostatic valve, straight      ② Thermostatic valve actuator      ③ Straight lockshield valve

**INSTALLATION FEATURES**

- Side with heat exchanger is always mounted closer to the window (wall)
- Energy carrier supply pipes has to be connected to heat exchangers connectors which are further from the fans
- Energy carrier outlet pipes has to be connected to heat exchangers connectors which are closer to the fans
- Height of the device can be adjusted at any time of exploitation (when installed in raised floor)

**ORDER CODES**

| Type | Length, cm | Width, cm | Height, cm | Example  |
|------|------------|-----------|------------|----------|
| FCH2 | 250        | 32        | 13         | FCH2 250 |

# FCH4

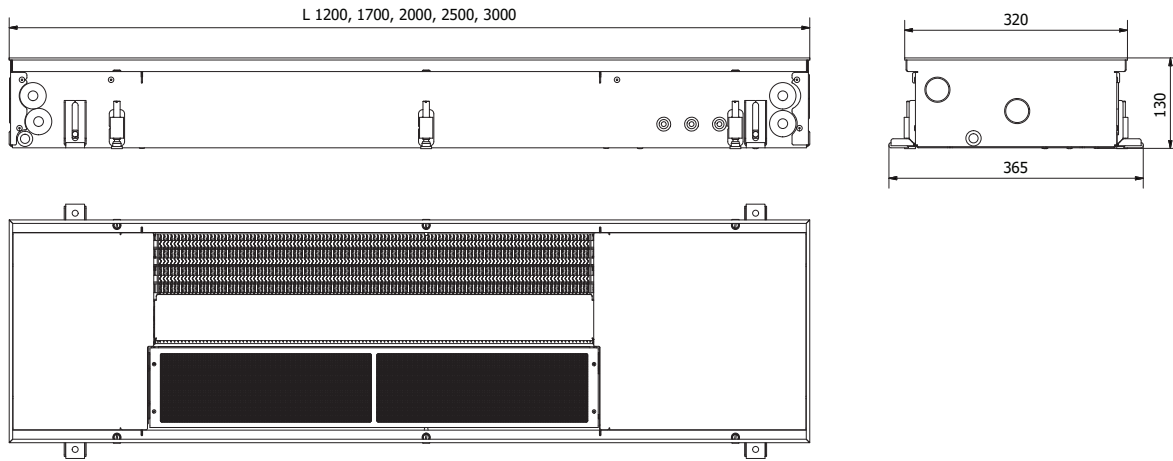

## TECHNICAL DATA

|                              |              |                                   |           |
|------------------------------|--------------|-----------------------------------|-----------|
| Length                       | 1200-3000 mm | Thread of hydr. connections       | G 1/2"    |
| Width                        | 320 mm       | Thread type of hydr. connections  | inner     |
| Height = installation height | 130 mm       | Position of the hydr. connections | 1 side    |
| Type of fan motors           | EC           | Operating pressure                | 25 bar    |
| Fan operating voltage        | 24V DC       | Operating temperature             | 2 - 120°C |
| Fan speed control voltage    | 0 - 10V      |                                   |           |

## EN16430 certified outputs

| Fan speed       | Heat outputs, W         |                         |                           | Sensible cooling capacity, W |                          |                          | Sound levels                |                          | Air flow m <sup>3</sup> /h |
|-----------------|-------------------------|-------------------------|---------------------------|------------------------------|--------------------------|--------------------------|-----------------------------|--------------------------|----------------------------|
|                 | 75/65/20°C<br>Δt = 50°C | 55/45/20°C<br>Δt = 30°C | 35/30/20°C<br>Δt = 12,5°C | 7/12/27°C<br>Δt = 17,5°C     | 7/12/25°C<br>Δt = 15,5°C | 14/17/25°C<br>Δt = 9,5°C | Sound pressure level, dB(A) | Sound power level, dB(A) |                            |
| <b>FCH4 115</b> |                         |                         |                           |                              |                          |                          |                             |                          |                            |
| 100%            | <b>2 013</b>            | 1 196                   | 490                       | 960                          | <b>857</b>               | 544                      | 41                          | 49                       | 0 - 383                    |
| 80%             | <b>1 859</b>            | 1 104                   | 452                       | 808                          | <b>722</b>               | 458                      | 36                          | 45                       |                            |
| 60%             | <b>1 661</b>            | 986                     | 404                       | 647                          | <b>578</b>               | 367                      | 28                          | 37                       |                            |
| 40%             | <b>1 380</b>            | 820                     | 336                       | 473                          | <b>423</b>               | 268                      | 23                          | 32                       |                            |
| 20%             | <b>901</b>              | 535                     | 219                       | 277                          | <b>247</b>               | 157                      | 20                          | 29                       |                            |
| <b>FCH4 160</b> |                         |                         |                           |                              |                          |                          |                             |                          |                            |
| 100%            | <b>3 624</b>            | 2 152                   | 881                       | 1 728                        | <b>1 542</b>             | 979                      | 42                          | 51                       | 0 - 520                    |
| 80%             | <b>3 347</b>            | 1 988                   | 814                       | 1 454                        | <b>1 299</b>             | 824                      | 41                          | 50                       |                            |
| 60%             | <b>2 989</b>            | 1 775                   | 727                       | 1 165                        | <b>1 040</b>             | 660                      | 34                          | 44                       |                            |
| 40%             | <b>2 485</b>            | 1 476                   | 604                       | 852                          | <b>761</b>               | 482                      | 29                          | 38                       |                            |
| 20%             | <b>1 623</b>            | 964                     | 395                       | 499                          | <b>445</b>               | 283                      | 25                          | 35                       |                            |
| <b>FCH4 180</b> |                         |                         |                           |                              |                          |                          |                             |                          |                            |
| 100%            | <b>4 026</b>            | 2 392                   | 980                       | 1 920                        | <b>1 714</b>             | 1 088                    | 44                          | 53                       | 0 - 766                    |
| 80%             | <b>3 718</b>            | 2 208                   | 904                       | 1 616                        | <b>1 444</b>             | 916                      | 39                          | 48                       |                            |
| 60%             | <b>3 322</b>            | 1 972                   | 808                       | 1 294                        | <b>1 156</b>             | 734                      | 31                          | 41                       |                            |
| 40%             | <b>2 760</b>            | 1 640                   | 672                       | 946                          | <b>846</b>               | 536                      | 24                          | 34                       |                            |
| 20%             | <b>1 802</b>            | 1 070                   | 438                       | 554                          | <b>494</b>               | 314                      | 22                          | 32                       |                            |
| <b>FCH4 230</b> |                         |                         |                           |                              |                          |                          |                             |                          |                            |
| 100%            | <b>5 637</b>            | 3 348                   | 1 371                     | 2 688                        | <b>2 399</b>             | 1 523                    | 43                          | 54                       | 0 - 903                    |
| 80%             | <b>5 206</b>            | 3 092                   | 1 266                     | 2 262                        | <b>2 021</b>             | 1 282                    | 40                          | 50                       |                            |
| 60%             | <b>4 650</b>            | 2 761                   | 1 131                     | 1 812                        | <b>1 618</b>             | 1 027                    | 33                          | 43                       |                            |
| 40%             | <b>3 865</b>            | 2 296                   | 940                       | 1 325                        | <b>1 184</b>             | 750                      | 26                          | 37                       |                            |
| 20%             | <b>2 524</b>            | 1 499                   | 614                       | 776                          | <b>692</b>               | 440                      | 24                          | 33                       |                            |

| Fan speed       | Heat outputs, W         |                         |                           | Sensible cooling capacity, W |                          |                          | Sound levels                |                          | Air flow m <sup>3</sup> /h |
|-----------------|-------------------------|-------------------------|---------------------------|------------------------------|--------------------------|--------------------------|-----------------------------|--------------------------|----------------------------|
|                 | 75/65/20°C<br>Δt = 50°C | 55/45/20°C<br>Δt = 30°C | 35/30/20°C<br>Δt = 12,5°C | 7/12/27°C<br>Δt = 17,5°C     | 7/12/25°C<br>Δt = 15,5°C | 14/17/25°C<br>Δt = 9,5°C | Sound pressure level, dB(A) | Sound power level, dB(A) |                            |
| <b>FCH4 275</b> |                         |                         |                           |                              |                          |                          |                             |                          |                            |
| 100%            | <b>7 248</b>            | 4 304                   | 1 762                     | 3 456                        | <b>3 084</b>             | 1 958                    | 43                          | 54                       | 0 - 1 040                  |
| 80%             | <b>6 694</b>            | 3 976                   | 1 628                     | 2 908                        | <b>2 598</b>             | 1 648                    | 42                          | 53                       |                            |
| 60%             | <b>5 978</b>            | 3 550                   | 1 454                     | 2 330                        | <b>2 080</b>             | 1 320                    | 33                          | 44                       |                            |
| 40%             | <b>4 970</b>            | 2 952                   | 1 208                     | 1 704                        | <b>1 522</b>             | 964                      | 27                          | 38                       |                            |
| 20%             | <b>3 246</b>            | 1 928                   | 790                       | 998                          | <b>890</b>               | 566                      | 24                          | 35                       |                            |

| Model    | Length, mm | No. of fans, pc | Max el. power, A | Max el. power, W | Length of heat exchanger, mm | Weight, kg | Water volume, l |         |
|----------|------------|-----------------|------------------|------------------|------------------------------|------------|-----------------|---------|
|          |            |                 |                  |                  |                              |            | Heating         | Cooling |
| FCH4 115 | 1 200      | 1               | 0,63             | 15               | 675                          | 21,2       | 0,17            | 0,60    |
| FCH4 160 | 1 700      | 1               | 0,75             | 18               | 1 189                        | 28,9       | 0,30            | 1,05    |
| FCH4 180 | 2 000      | 2               | 1,25             | 30               | 1 431                        | 33,9       | 0,36            | 1,26    |
| FCH4 230 | 2 500      | 2               | 1,38             | 33               | 1 945                        | 42,2       | 0,49            | 1,72    |
| FCH4 275 | 3 000      | 2               | 1,50             | 36               | 2 458                        | 51,5       | 0,62            | 2,17    |

FCH4

### EXAMPLE OF CONNECTIONS

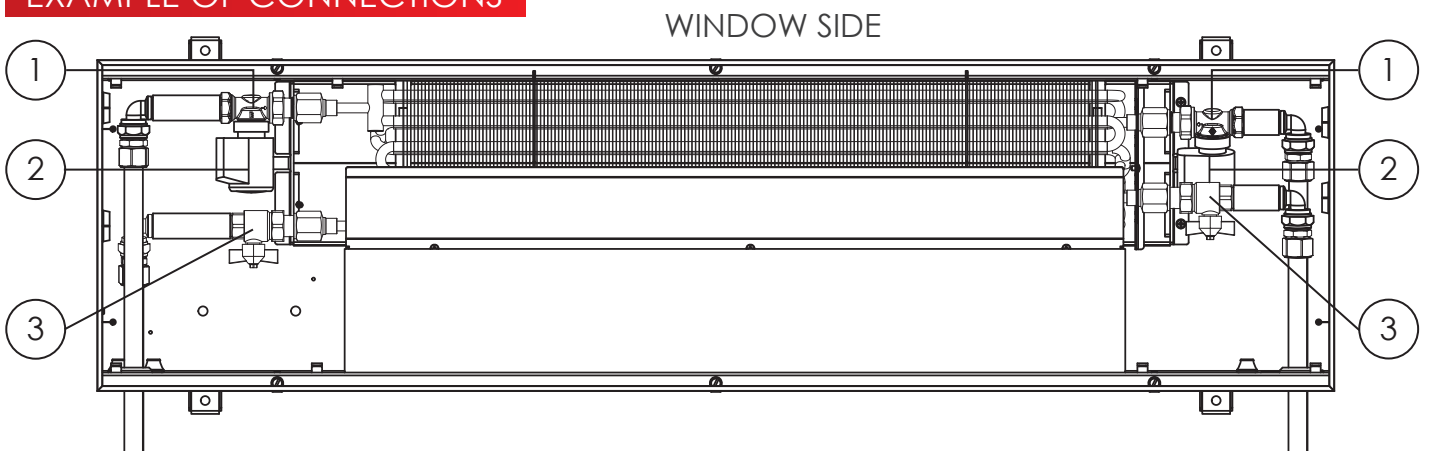

- ① Thermostatic valve, straight    ② Thermostatic valve actuator    ③ Straight lockshield valve

### INSTALLATION FEATURES

- The side with the heat exchanger is always mounted closer to the window (wall)
- Possibility to connect pipes through the side or end of the convector
- The 4-pipe heat exchanger has two independent circuits. They are connected to the heating and cooling systems on both sides of the device as follows:
  - To a cooling system – on a side of the control box;
  - To a heating system – on a side of condensate water outlet.
- Energy carrier supply have to be connected to heat exchanger connection which is further from fans
- Outgoing pipes of both circuits have to be connected to the heat exchanger's connections which is closer to fans
- All fasteners required for mounting are included in the standard kit
- The possibility of adjusting the height of the device after mounting (when mounting into raised floor)

### ORDER CODES

| Type | Length, cm | Width, cm | Height, cm | Example  |
|------|------------|-----------|------------|----------|
| FCH4 | 250        | 32        | 13         | FCH4 250 |

## ACCESSORIES

### THERMOSTATIC VALVE **TVS15**

Controls flow of energy carrier. Controlled by thermal actuator TA24



Controls flow with thermoelectric actuator

Provides possibility to close flow and disconnect heat exchanger from heating system without draining

DN15 Kvs = 2,00

### LOCKSHIELD VALVE (STRAIGHT) **LS15**

Opens, closes or limits flow of energy carrier



For energy carrier opening, closing and presetting of maximal flow

Provides possibility to close flow and disconnect heat exchanger from heating system without draining

DN15 Kvs = 1,74

DN20 Kvs = 1,93

### LOCKSHIELD VALVE (ANGLE) **LA15**

Opens, closes or limits flow of energy carrier



For energy carrier opening, closing and presetting of maximal flow

Provides possibility to close flow and disconnect heat exchanger from heating system without draining

DN15 Kvs = 1,74

DN20 Kvs = 1,93

### THERMOSTATIC VALVE ACTUATOR **TA24**

Opens / closes thermostatic valve. Controlled by room thermostat RTB24



Opening/closing of thermostatic valves (ON/OFF)

Thermoelectric

Opened/Closed indicator

Voltage 24V DC

### ROOM THERMOSTAT **RTB24**

Controls thermal actuator TA24 and fans according to preset room temperature



For maintaining the set room temperature

Day/night and weekly temperature programmes

Accuracy of temperature control  $\pm 0,5^{\circ}\text{C}$

Power supply of 24V DC

Stepless fan rotating speed control, 0-10 V

Valve actuator control (ON/OFF)

Backlit LED display

### ELECTRIC CONTROL BOX **CB20**

For power supply of fans, actuators TA24 and room thermostat RTB24

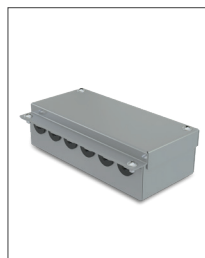

Can be installed inside convector's casing

Ensures easy and fast connection between convector and room thermostat

24V DC power supply included

El. connectors for fast connection of the cables included

## ORDER CODES

| Accessory                   | Order code |
|-----------------------------|------------|
| Thermostatic valve          | TVS15      |
| Thermostatic valve actuator | TA24       |
| Lockshield valve (angle)    | LA15       |
| Lockshield valve (straight) | LS15       |
| Room thermostat             | RTB24      |
| Electric control box        | CB20       |

## CONNECTING ONE FCH TO ROOM THERMOSTAT

ROOM THERMOSTAT **RTB24**

TRENCH HEATER **FCH**

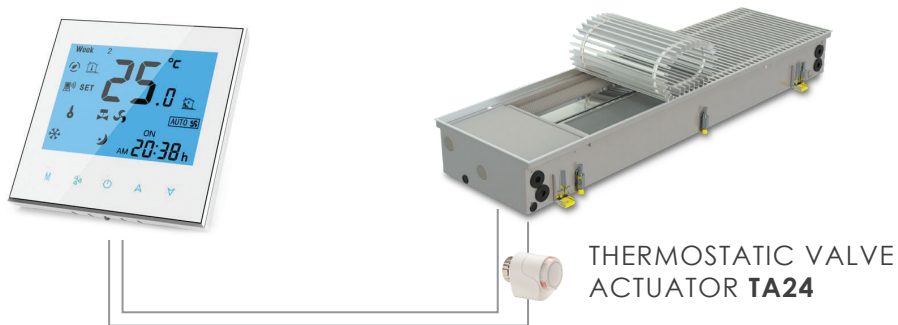

## CONNECTING MULTIPLE FCH TO ROOM THERMOSTAT

ROOM THERMOSTAT **RTB24**

TRENCH HEATERS **FCH** (UP TO 30 PCS)

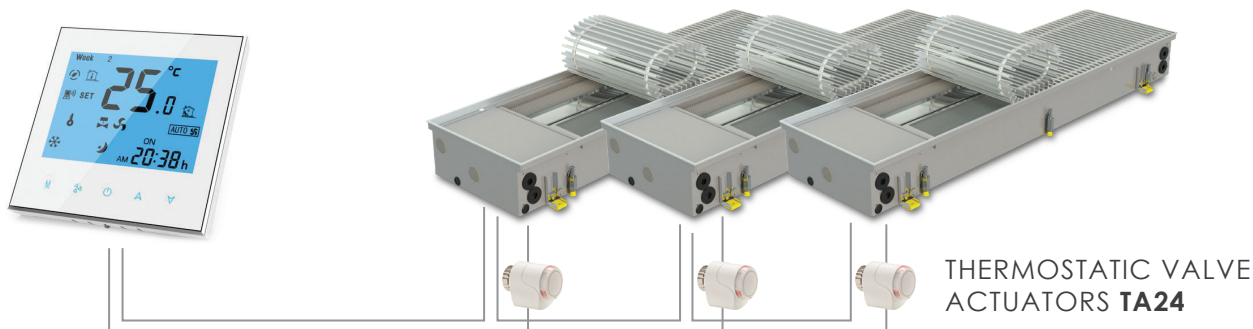

## WIRING DIAGRAM

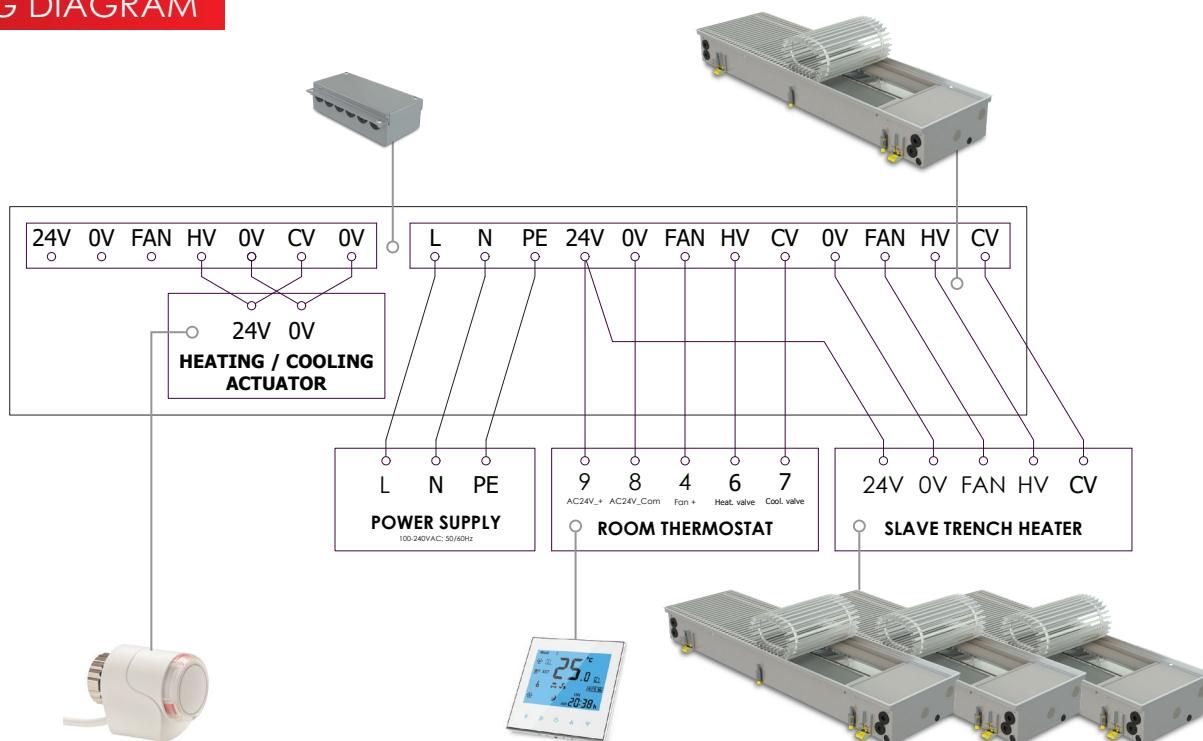

- Trench heaters installed in the same room are controlled based on the Master - Slave principle
- Speed of fans are controlled 0-10 V by room thermostat. Voltage – 24VDC

- Valve actuators are controlled ON/OFF by room thermostat. Voltage – 24VDC
- Up to 30 trench heaters can be controlled with one room thermostat RTB24

# GRILLES

## ALUMINIUM ROLL-UP GRILLES

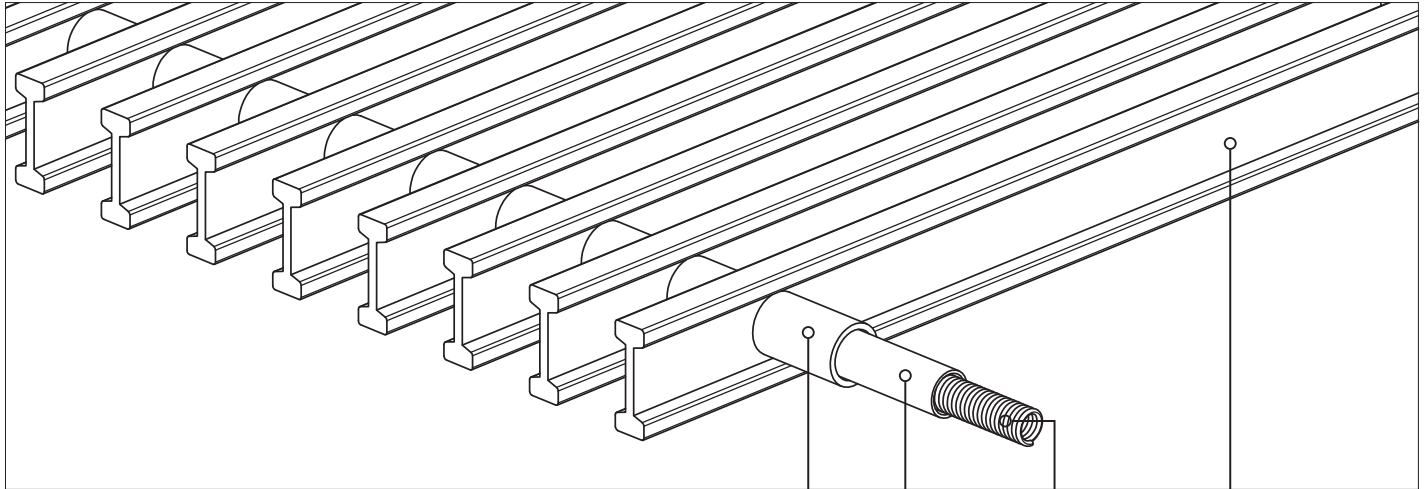

GRILLE PROFILE

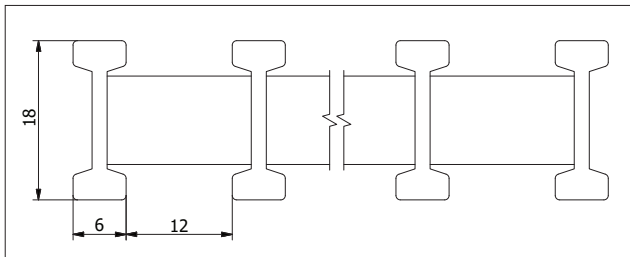

GRILLES

### ① Aluminium profile

- made of anodized aluminium
- reinforced reversible double T profile

### ② Spacers

- made of anodized aluminium
- does not shrink or crack when exposed on UV or heat
- the colour is exactly the same as colour of profiles

### ③ Spring

### ④ Flexible protective pipe

SILVER (ALS)



BROWN (AL 10)

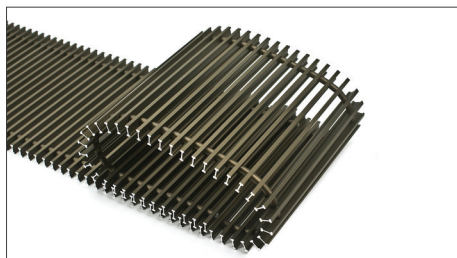

BLACK (AL 50)

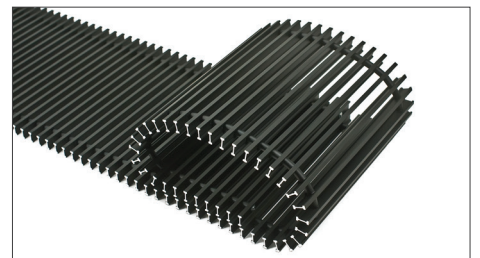

## ALUMINIUM LINEAR GRILLES

SILVER (ALS)



BROWN (AL 10)

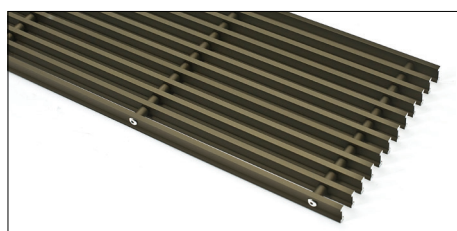

BLACK (AL 50)



## WOODEN ROLL-UP GRILLES

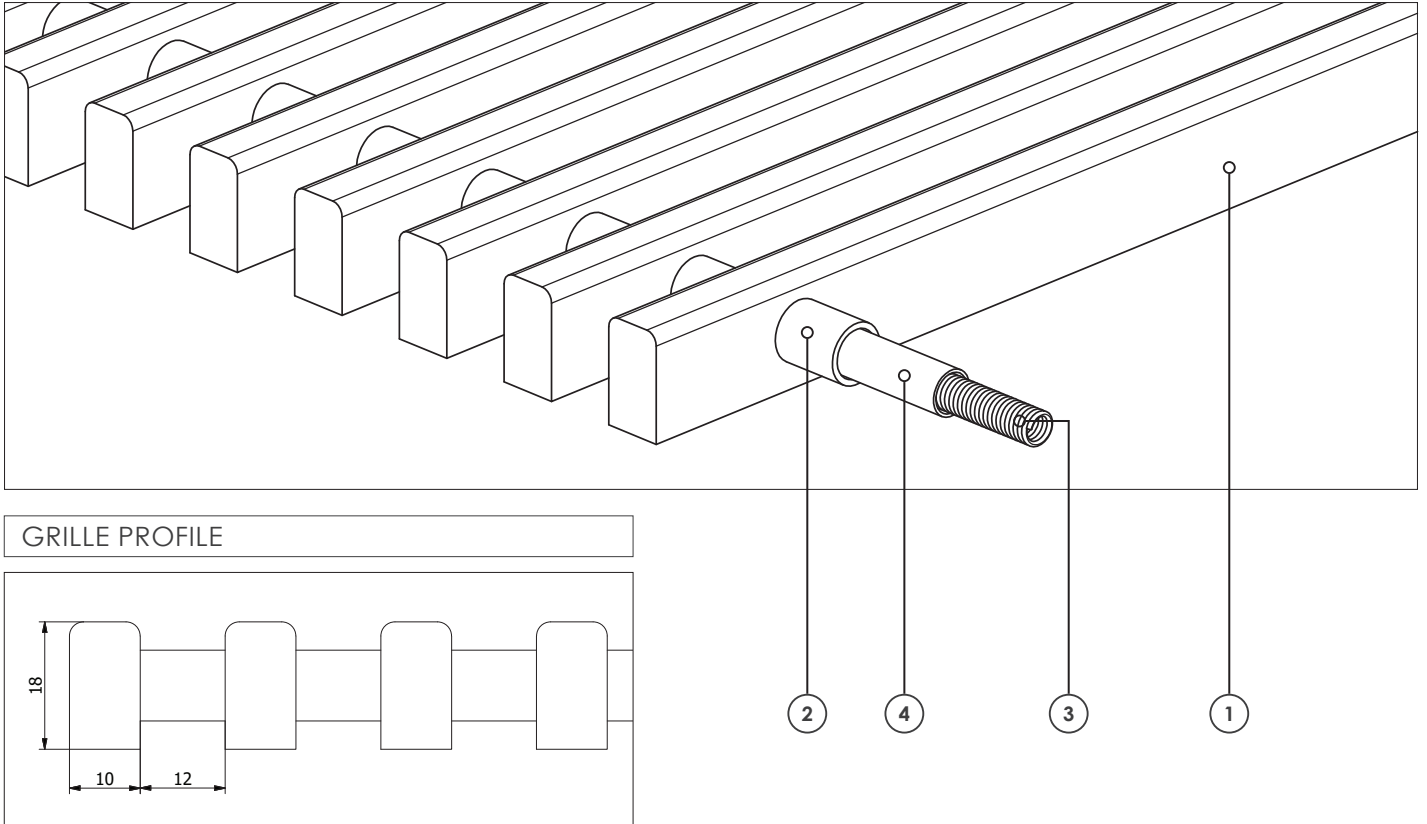

① **Wooden profile**  
- made of solid wood

② **Spacers**  
- made of anodized aluminium  
- does not shrink or crack when exposed on UV or heat

③ **Spring**

④ **Flexible protective pipe**

OAK

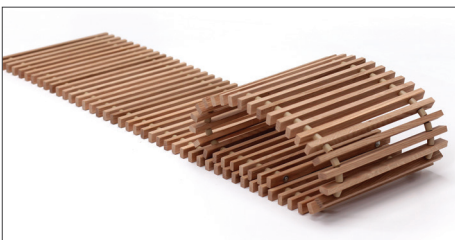

ASH

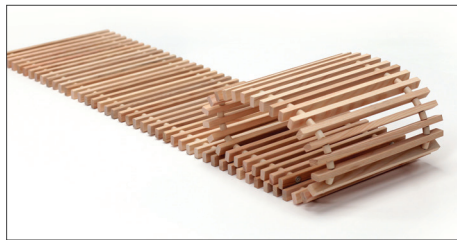

BEECH

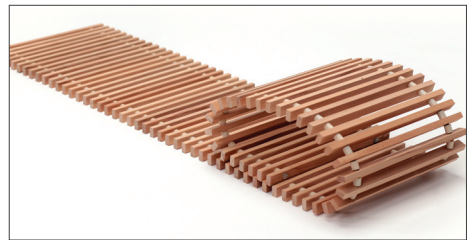

## ORDER CODE FOR GRILLES

| Type | Length, cm | Width, cm | Material | Example       |
|------|------------|-----------|----------|---------------|
| GR   | 200        | 32        | ALS      | GR 200-32 ALS |



**@ Envi Group Romania**

Country: Romania  
City: Bucharest  
Address: 15 Tudor Vladimirescu  
Boulevard  
Postal code: 050881  
Website: [www.envi-group.ro](http://www.envi-group.ro)  
Email: [office@envi-group.ro](mailto:office@envi-group.ro)  
Landline: +40 31 421 11 16

